

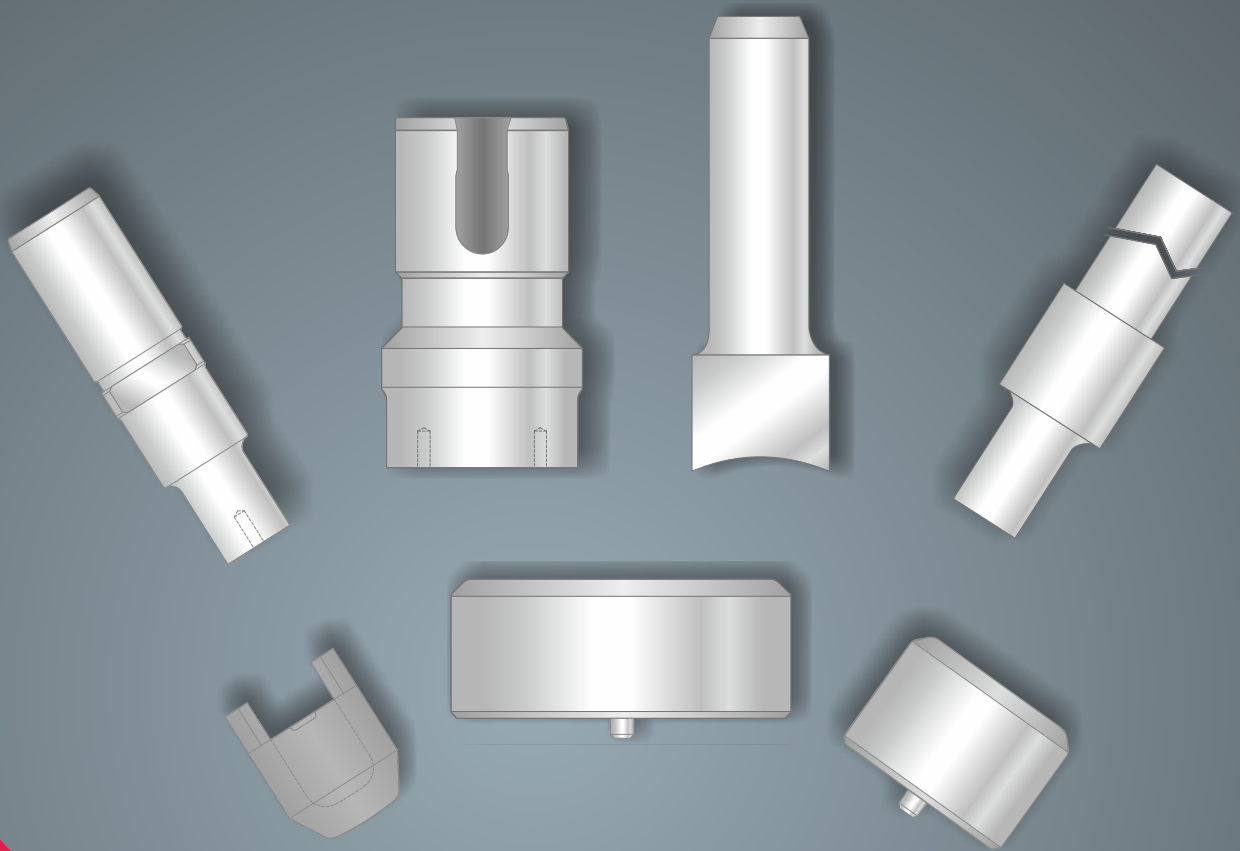

# MURATA WIEDEMANN TOOLING

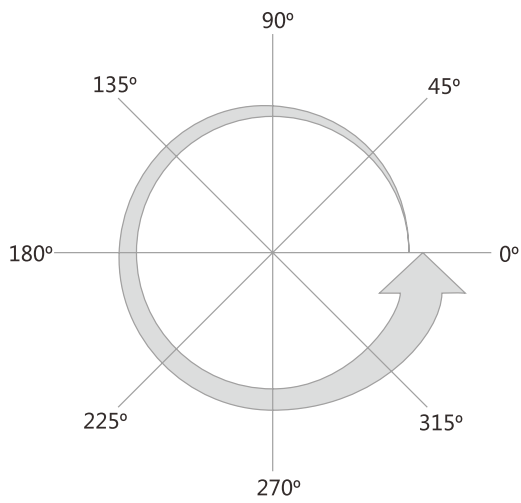

AFAB MACHINERY AND TOOLS LTD



SHAPE ANGLE DIRECTION

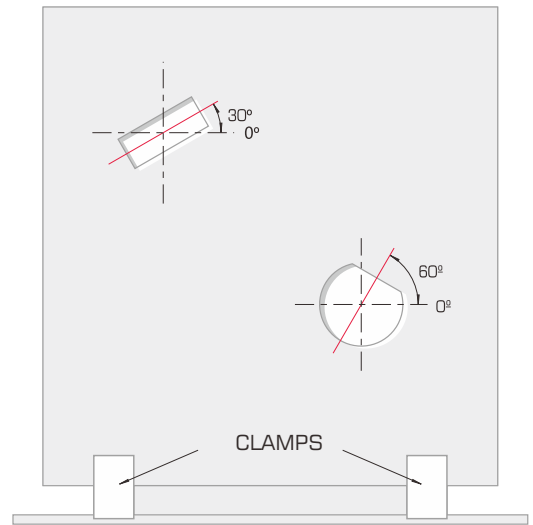

SHAPE POSITION AT SHEET METAL FROM TOP OF MACHINE

STANDARD SHAPE KEY LOCATION

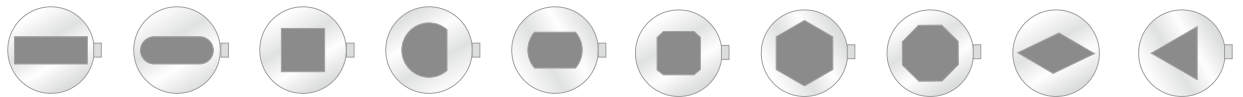

10 STANDARD SHAPES(same price)

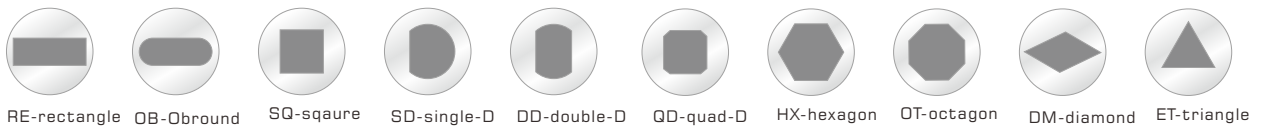

PUNCH TIP TYPE

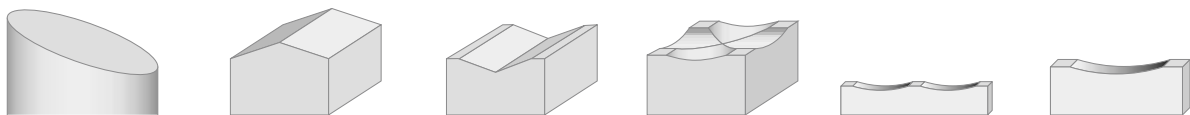

Whisper

Rooftop

Inverted Rooftop

4 way concave

2 way concave

Cup concave

# TECHNICAL INFORMATION

114 TOOLING SYSTEM

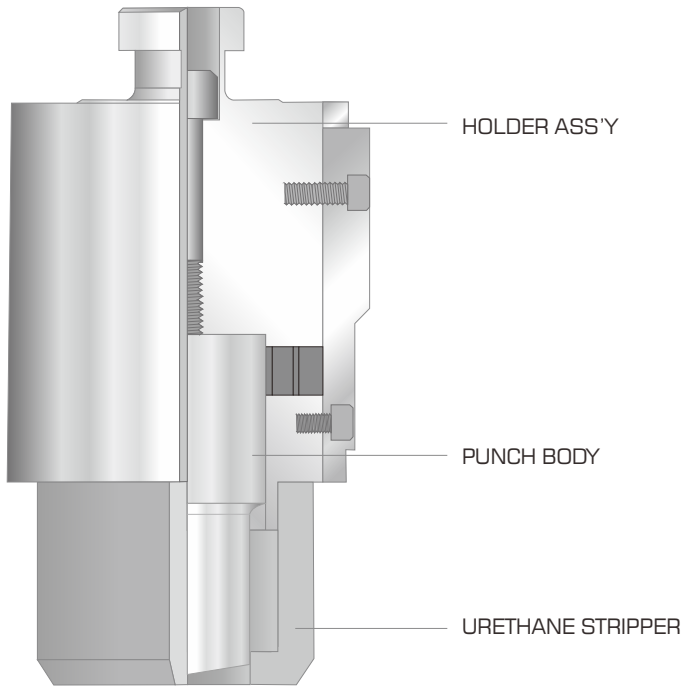

VULCAN TOOLING SYSTEM

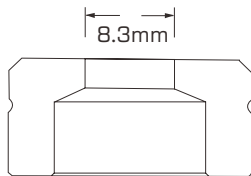
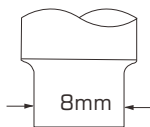
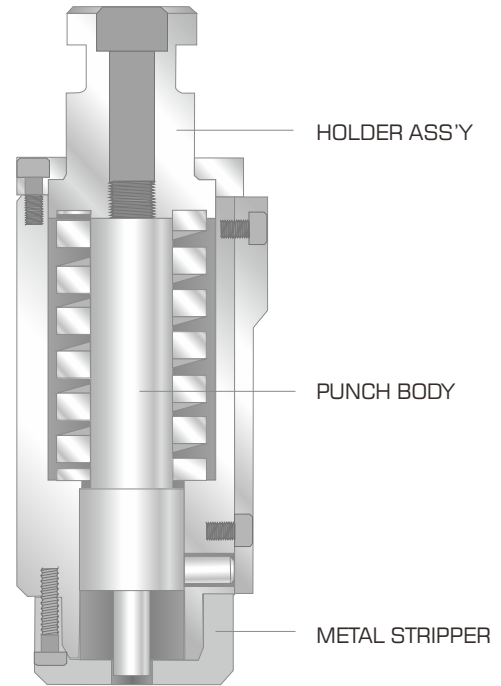

.8.3-8mm = 0.3mm = Total Clearance

Recommended Total Die Clearance

Material Thickness	Aluminum Total Clearance	Mild Steel Total Clearance	Stainless Steel Total Clearance
1.00	0.15	0.20	0.20
1.50	0.23	0.30	0.40
2.00	0.30	0.40	0.50
3.00	0.60	0.75	0.90
4.00	0.80	1.00	1.20
5.00	1.00	1.25	1.75
6.35	1.60	2.00	2.22

## 1 14 TOOLING SYSTEM, A/B/C STATION

### A STATION (~ 12.7mm)

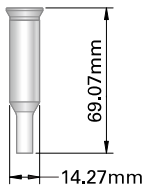

Punch  
round: W4-APBRO

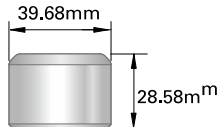

Die  
round: W4-ADIRO

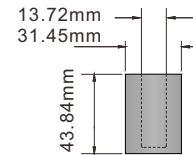

Stripper  
W4-AST

### B STATION (~ 25.4)mm

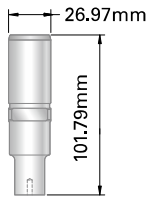

Punch  
round: W4-BPBRO  
shape: W4-BPB\*\*

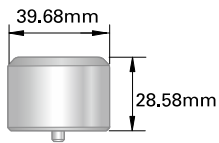

Die  
round: W4-BDIRO  
shape: W4-BDI\*\*

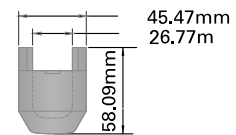

Stripper  
W4-BST

### C STATION ( 25.4 ~ 38.1 mm)

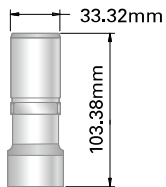

Punch  
round: W4-CPBRO  
shape: W4-CPB\*\*

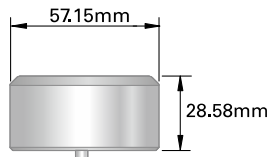

Die  
round: W4-CDIRO  
shape: W4-CDI\*\*

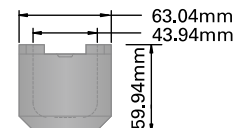

Stripper  
W4-CST

### D STATION(38.1~50.8mm)

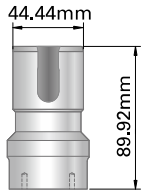

Punch  
round:W4-DPBRO  
shape:W4-DPB\*\*

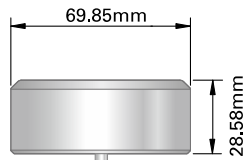

Die  
round:W4-DDIRO  
shape:W4-DDI\*\*

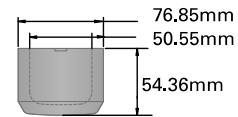

Stripper  
W4-DST

### E STATION (50.8~63.5mm)

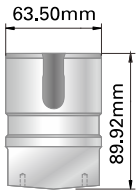

Punch  
round:W4-EPBRO  
shape:W4-EPB\*\*

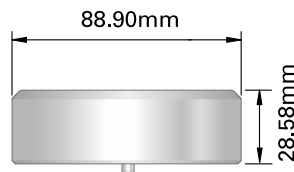

Die  
round:W4-EDIRO  
shape:W4-EDI\*\*

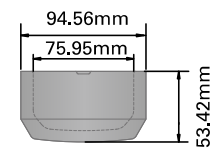

Stripper  
W4-EST

### F STATION(63.5~76.2mm)

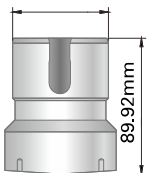

Punch  
round:W4-FPBRO  
shape:W4-FPB\*\*

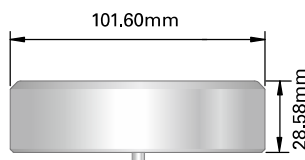

Die  
round:W4-FDIRO  
shape:W4-FDI\*\*

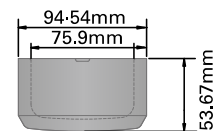

Stripper  
W4-FST

### G STATION(76.2~88.9mm)

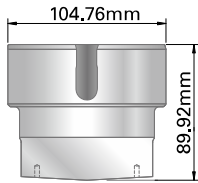

Punch  
round:W4-GPBRO  
shape:W4-GPB\*\*

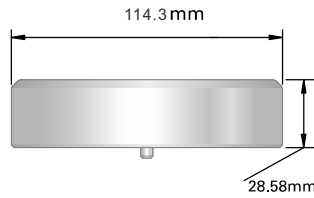

Die  
round:W4-GDIRO  
shape:W4-GDI\*\*

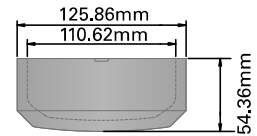

Stripper  
W4-GST

### H STATION(88.9~104.8mm)

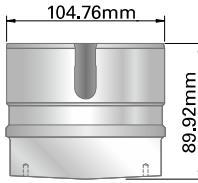

Punch  
round:W4-HPBRO  
shape:W4-HPB\*\*

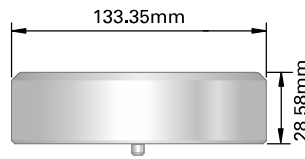

Die  
round:W4-HDIRO  
shape:W4-HDI\*\*

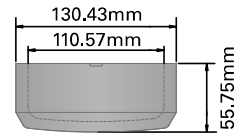

Stripper  
W4-HST

### J STATION (104.8~120.6mm)

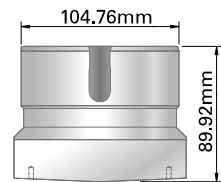

Punch  
round:W4-JPBRO  
shape:W4-JPB\*\*

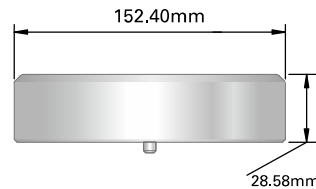

Die  
round:W4-JDIRO  
shape:W4-JDI\*\*

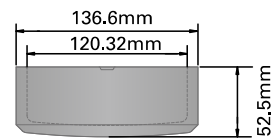

Stripper  
W4-JST

## VULCAN TOOLING SYSTEM, X/AB/C STATION

## X STATION (~ 12.7mm)

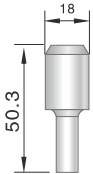

Punch  
round: WV-XPBRO

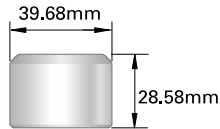

Die  
round: WV-XDIRO

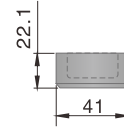

Stripper  
WV-XST

## AB STATION (~ 25.4mm)

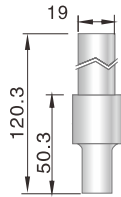

Punch  
round: WV-APBRO  
shape: WV-APB\*\*

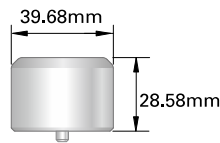

Die  
round: WV-ADIRO  
shape: WV-ADI\*\*

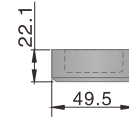

Stripper  
round: WV-ASTRO  
shape: WV-AST\*\*

## C STATION (25.4 ~ 38.1 mm)

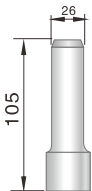

Punch  
round: WV-CPBRO  
shape: WV-CPB\*\*

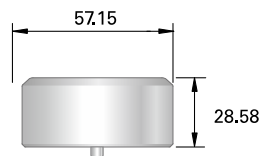

Die  
round: WV-CDIRO  
shape: WV-CDI\*\*

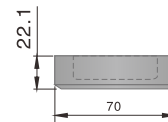

Stripper  
round: WV-CSTRO  
shape: WV-CST\*\*

## D STATION(38.1~50.8mm)

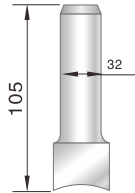

Punch  
round:WV-DPBRO  
shape:WV-DPB\*\*

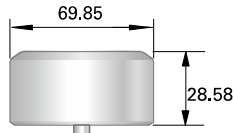

Die  
round:WV-DDIRO  
shape:WV-DDI\*\*

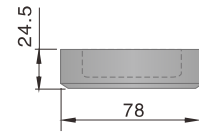

Stripper  
round:WV-DSTRO  
shape:WV-DST\*\*

## E STATION(50.81~63.5mm)

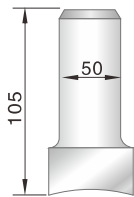

Punch  
round:WV-EPBRO  
shape:WV-EPB\*\*

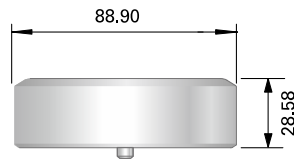

Die  
round:WV-EDIRO  
shape:WV-EDI\*\*

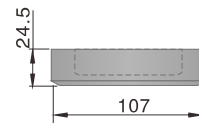

Stripper  
round:WV-ESTRO  
shape:WV-EST\*\*

## F STATION(63.5~76.2mm)

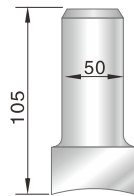

Punch  
round:WV-FPBRO  
shape:WV-FPB\*\*

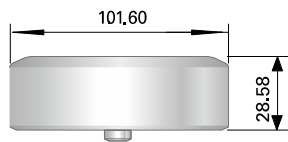

Die  
round:WV-FDIRO  
shape:WV-FDI\*\*

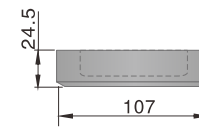

Stripper  
round:WV-FSTRO  
shape:WV-FST\*\*



## G STATION(76.21~88.9mm)

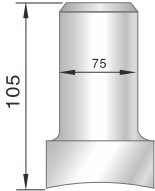

Punch  
round: WV-GPBRO  
shape: WV-GPB\*\*

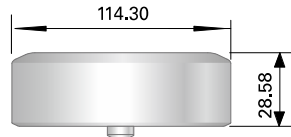

Die  
round: WV-GDIRO  
shape: WV-GDI\*\*

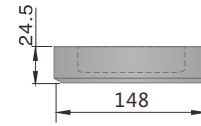

Stripper  
round: WV-GSTRO  
shape: WV-GST\*\*

## H STATION(88.9~104.8mm)

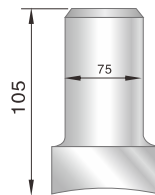

Punch  
round: WV-HPBRO  
shape: WV-HPB\*\*

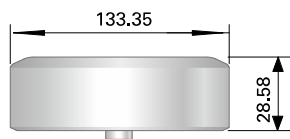

Die  
round: WV-HDIRO  
shape: WV-HDI\*\*

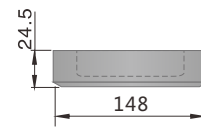

Stripper  
round: WV-HSTRO  
shape: WV-HST\*\*

## J STATION(104.8~120.65mm)

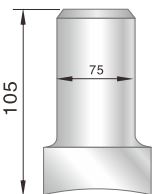

Punch  
round: WV-JPBRO  
shape: WV-JPB\*\*

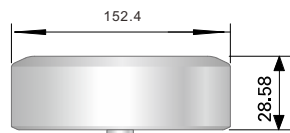

Die  
round: WV-JDIRO  
shape: WV-JDI\*\*

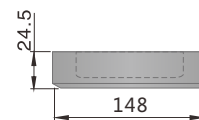

Stripper  
round: WV-JSTRO  
shape: WV-JST\*\*

## SPECIAL SHAPES

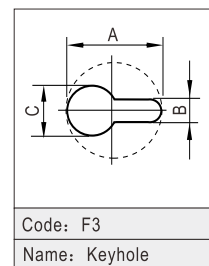
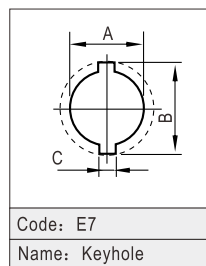
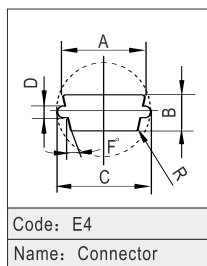
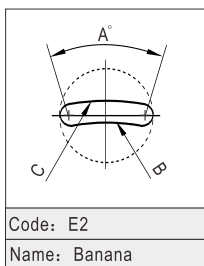
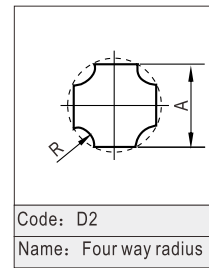
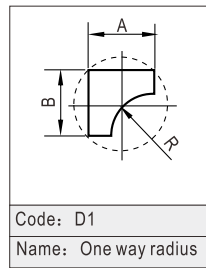
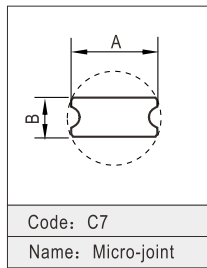
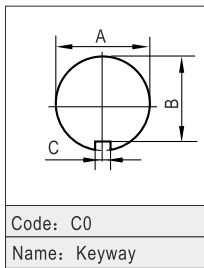
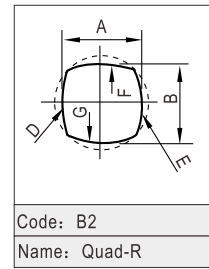
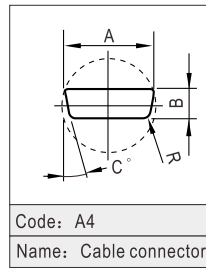
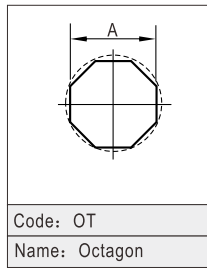
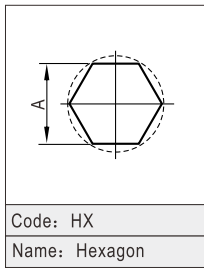
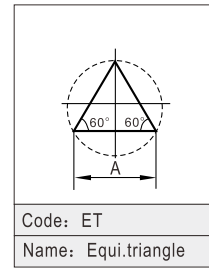
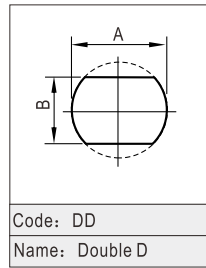
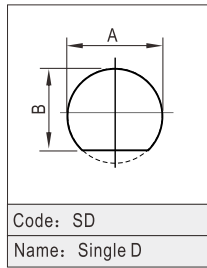
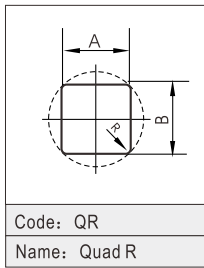

## PUNCH DIE GRINDER



Punch die grinder specification.

Grinding accuracy: $\pm 0.005\text{mm}$	Tool setting mode: Automatic
Grinding mode: Automatic	Grinding type: Rough, Precision, Polishing
Wheel: Boronizing wheel	Grinding area: 150mm
3-jaw chuck fixture Dia. 1-180mm	Max. feed speed: 900mm/min (adjustable)
PLC controller: Mitsubishi	Screen: Touch screen Interface
Spindle motor: 2.2KW, 3600R/PM	Motor for rotating table: 0.375KW, 1800R/PM
Motor for cooling : 0.125KW, 1800R/PM	Electrical: AC380/400V (50/60 HZ)
Size: 600x700x1650mm	Weight: 600KG

# AFAB TOOLING

AFAB MACHINERY AND TOOLS LTD.  
Email:[export@afabmt.com](mailto:export@afabmt.com)  
website:[www.afabmt.com](http://www.afabmt.com)