

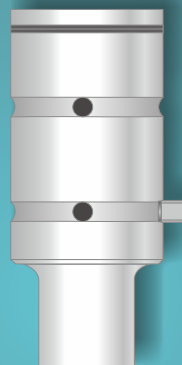

THIN TURRET TOOLING-Strippit

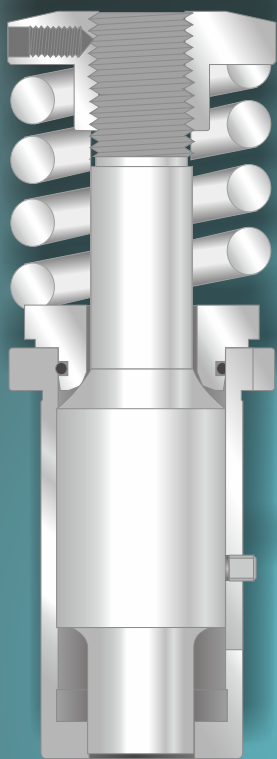

AFAB MACHINERY AND TOOLS LTD

1

Drop In Type 5/8" Station (max. Diameter/diagonal 15.8mm)

AEAB THIN TURRET

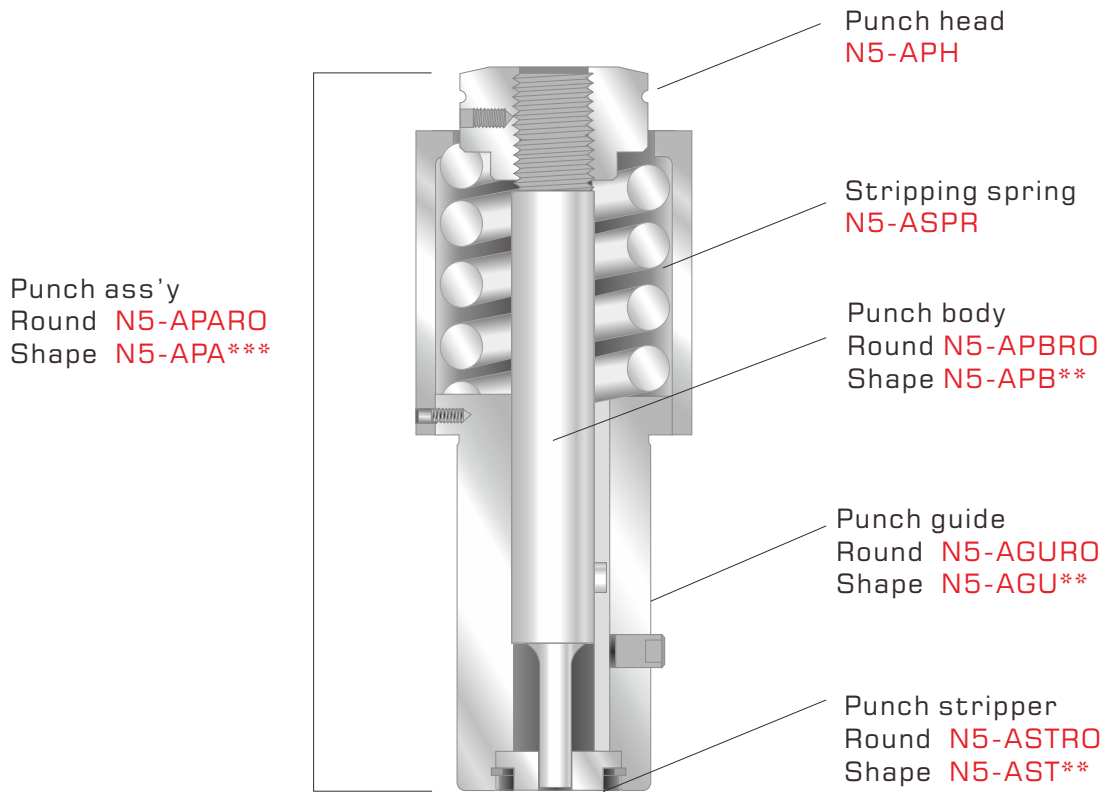

DIE
Round N8-BDIRO
Shape N8-BDI**



STANDARD SHAPE KEY LOCATION



2

S80 Type 1-1/4" Station (max. Diameter/diagonal 31.7mm)

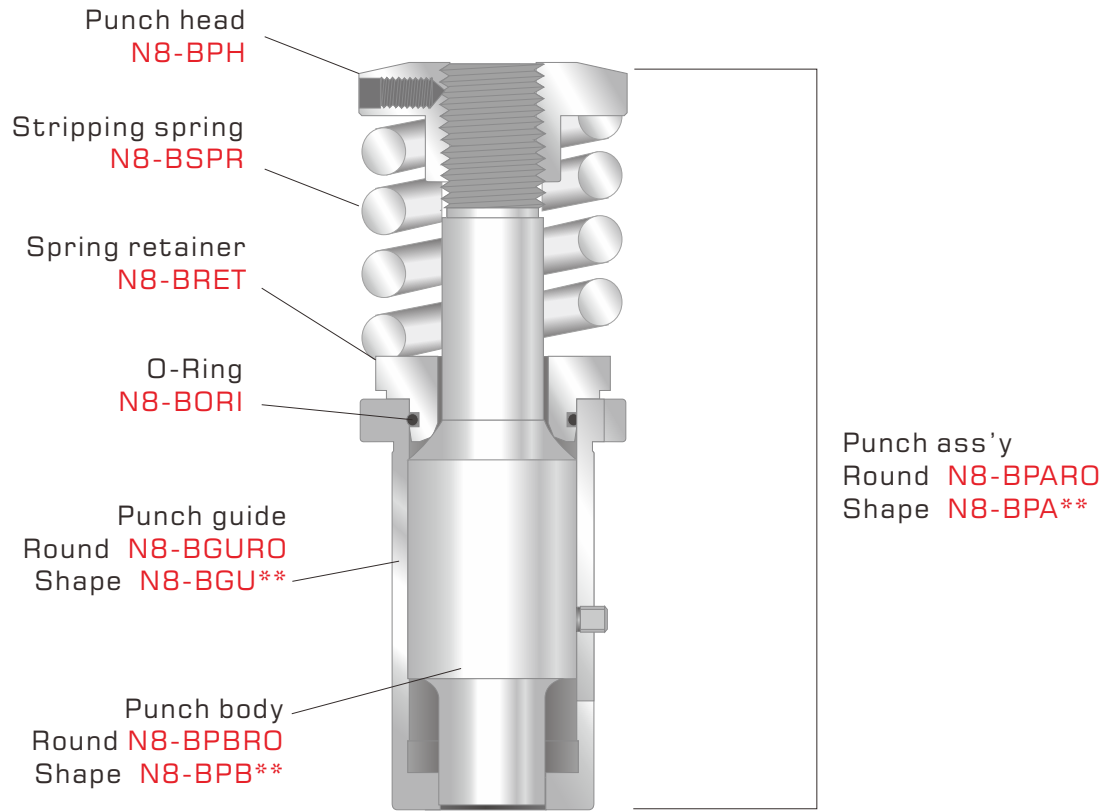

DIE
Round N8-BDIRO
Shape N8-BDI**

10 STANDARD SHAPES(same price)



RE-rectangle



OB-obround



SQ-square



SD-single-D



DD-double-D



QD-quad-D



HX-hexagon



OT-octagon



DM-diamond



ET-triangle

AFAB THIN TORRET

S90 Type 1-1/4" Station (max. Diameter/diagonal 31.7mm)

AFAAB THIN TURRET

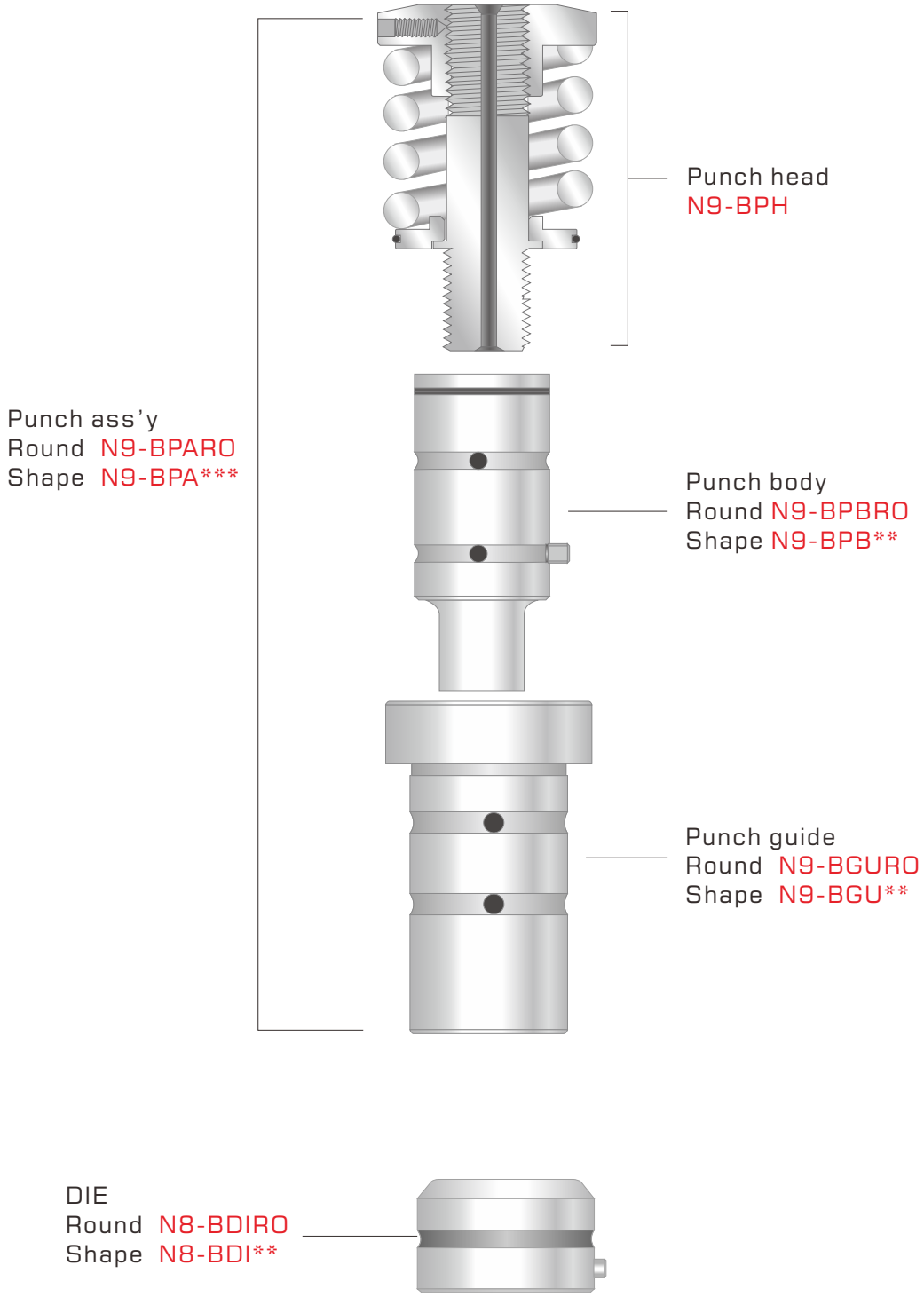

MINI. RELIABLE SIZE TO PUNCH

	Material	Mini. A size (mm)
	Stainless steel	2xT (thickness)
	Mild steel	1xT (thickness)
	Alumium	1xT (thickness)

eg. SS material, not recommended to punch 1.5 Dia hole

TYPE OF PUNCH TIP

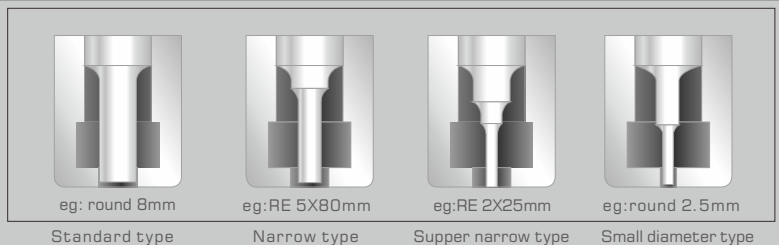

4

S90 type 3-1/2" STATION(max. Diameter/diagonal 88.9mm)

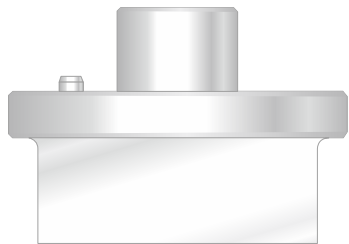
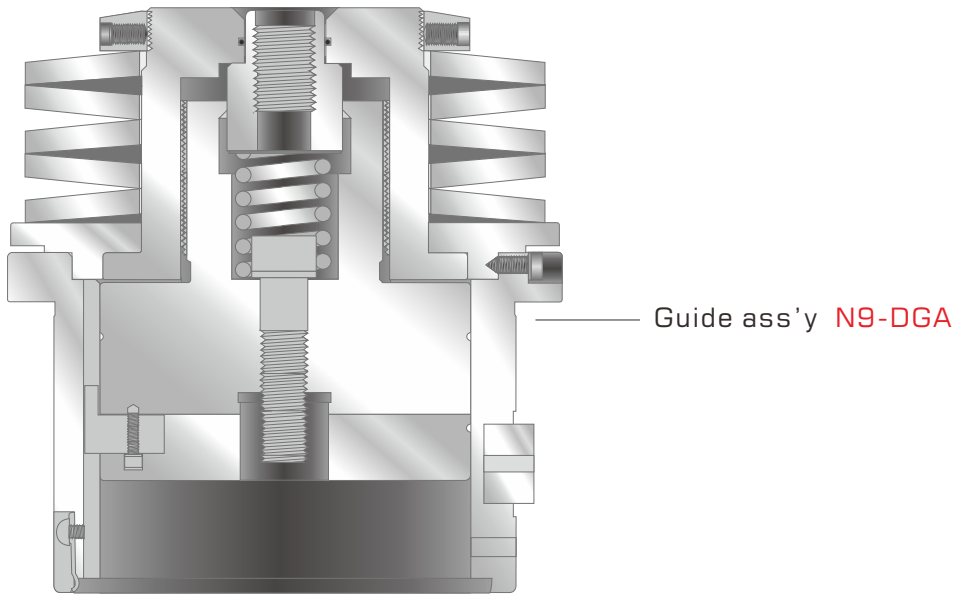

Punch body < 50.8mm
Round N9-DPB1RO
Shape N9-DPB1**

Punch body < 88.9mm
Round N9-DPB1RO
Shape N9-DPB1**



Stripper
Round N9-DSTRO
Shape N9-DST**



Die
Round N8-DDIRO
Shape N8-DDI**

AFAB THIN TURRET

AFAB MACHINERY AND TOOLS LTD.

Email: sales@afabmt.com

website: www.afabmt.com

AFAB TOOLING

AFAB MACHINERY AND TOOLS LTD.
Email:export@afabmt.com
webite:www.afabmt.com